

Laura's Gourmet

SIMPLIFIED
ELEVATED
PERFECTED

CounterCool[®]

BY LAURA'S GOURMET

AMPLE STORAGE & HEAVY-DUTY PERFORMANCE

CounterCool by Laura's Gourmet is engineered to meet the demands of busy culinary environments. Featuring slide rails spaced 3" apart, this rack ensures optimal air circulation around your foods—ideal for cooling baked goods, storing prepped ingredients, or staging plated dishes. With a robust 40 lb. total weight capacity and support for up to 8 lb. per pair of slides, CounterCool offers exceptional durability and strength for commercial use.

Whether you're operating a restaurant, bakery, catering service, or culinary classroom, this half-height rack is the perfect solution for a variety of operations. Its sturdy metal frame is built to withstand daily wear and tear, making it a reliable choice for supporting pans filled with cookies, pastries, roasted meats, or other prepared foods throughout the kitchen area and its portability makes use off premise simple and easy.

DIMENSIONS & MATERIAL SPECIFICATIONS

- Overall Dimensions Open: 19 1/2" x 15 3/8" x 15 1/2" H
- Overall Dimensions Folded: 19 1/2" x 5" x 15 1/2"
- Pan Capacity: Holds up to 5 half-size sheet pans, 10 quarter-size sheet pans or any combination.
- Slide Spacing: 3" between rails
- Weight Capacity: 40 lb. total; 8 lb. per pair of slides
- Material: High-strength food grade aluminum construction for lightweight durability and corrosion resistance
- Load Style: End-load design for easy access and efficient workflow
- Mobility: Patented hinging design allows easy collapsibility
- Product Weight: 4 lb 5 oz. Gross Weight for shipping: 5 lb 5 oz



CONTINUED ➔

Laura's
Gourmet

SIMPLIFIED
ELEVATED
PERFECTED

CounterCool[®]

BY LAURA'S GOURMET

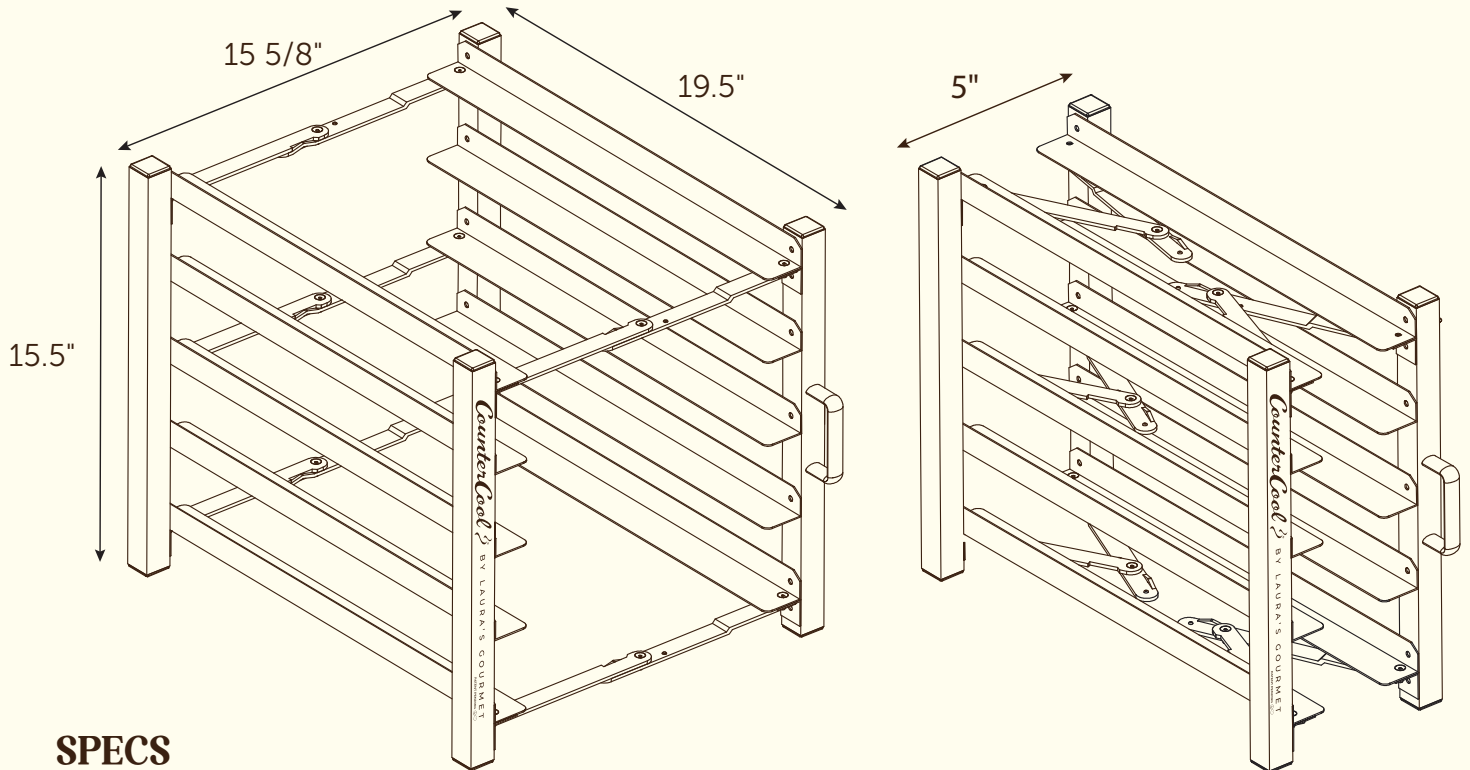

SPECS

Quantity	1/Each
Shipping Weight	5.4 lb
Length Open	19 1/2 Inches
Width Open	15 3/8 Inches
Height Open	15 1/2 Inches
Length Closed	19 1/2 Inches
Width Closed	5 Inches
Height Closed	15 1/2 inches
Height Style	Five Slide Rails
Manufacturer	
Product Code:	CCCR
UPC	850061762368

Assembly Options	Assembly NOT Required
Capacity (per Shelf)	8 lb.
Color	Silver
Features	Freezer Safe Food Grade Aluminum
Installation Type	On Counter
Loading Style	End Load
Material	Aluminum
Pan Capacity	5 half sheet or 10 quarter sheet or any combination
Pan Type	Half and Quarter Sheet Pans
Rack Style	Bun Pan
Shelf / Ledge Spacing	3 Inches
Style	Open
Total Capacity	40 lb.
Type	Sheet Pan Racks

